

## Product Specifications

Housing and End Cap Material	Steel
Standard Port Size	SAE #32 O-Ring
Piston Material	Aluminum
Sealing Material	Buna-N
Back-Up/ Wear Ring Material	Teflon
Gas Valve Material	Stainless Steel
Max Working Pressure	3,000 psi (206 bar)
Proof Pressure	3,900 psi (269 bar)
Burst Pressure	12,000 psi (827 bar)
Temp. Range (ASME)	20°F to 200°F (-6°C to 93°C)
Temp. Range (CE)	0°F to 200°F (-17°C to 93°C)
Seal Kit Part Number	KT-207940

## Parts Legend

Item	Description
A	Gas Cap
B	Housing
C	Piston
D	Oil Cap
E	O-Rings (2 req'd)
F	Piston Seal
G	Wear Ring
H	Back-Up Rings (2 req'd)

**Designed per  
ASME,  
Section VIII, Div. 1  
Standards**

# A70 Series

**7.0" bore, 3000 psi  
Piston Accumulators**

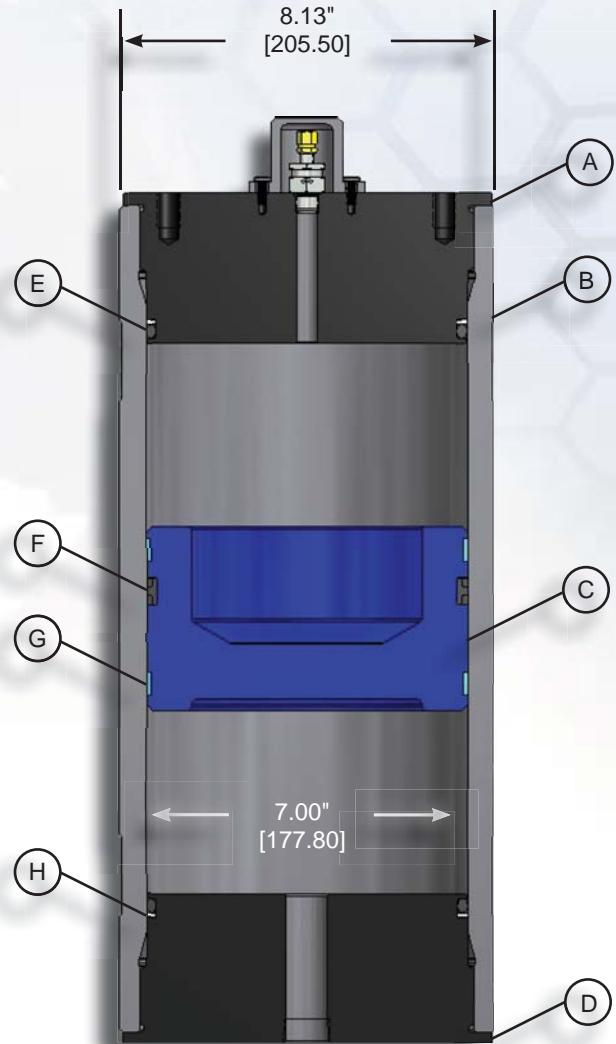

## Model Variations

Model No.	Nominal Size		Oil Volume		Gas Volume		Overall Length*		Weight	
	gal	liters	in <sup>3</sup>	liters	in <sup>3</sup>	liters	in	mm	lbs	kg
A70-0578-3K-B-32S	2.50	9.47	578	9.47	627	10.28	30.57	776.48	215	98
A70-1155-3K-B-32S	5.00	18.93	1155	18.93	1204	19.73	45.57	1157.48	270	122
A70-1733-3K-B-32S	7.50	28.40	1733	28.40	1782	29.21	60.57	1538.48	327	148
A70-2310-3K-B-32S	10.00	37.86	2310	37.86	2359	38.66	75.57	1919.48	385	175
A70-3465-3K-B-32S	15.00	56.79	3465	56.79	3514	57.59	105.57	2681.48	500	227
A70-4620-3K-B-32S	20.00	75.72	4620	75.72	4669	76.52	135.56	3443.23	615	279
A70-5775-3K-B-32S	25.00	94.65	5775	94.65	5824	95.46	165.82	4211.83	727	330
A70-6930-3K-B-32S	30.00	113.58	6930	113.58	6979	114.39	195.82	4973.83	840	381

\*Length shown includes 1.656" for gas valve cover.

FORM: A703K B